

# Modified drop shoulder 24"

Tension

$$7.5st = 1''$$

$$10.5rows = 1''$$

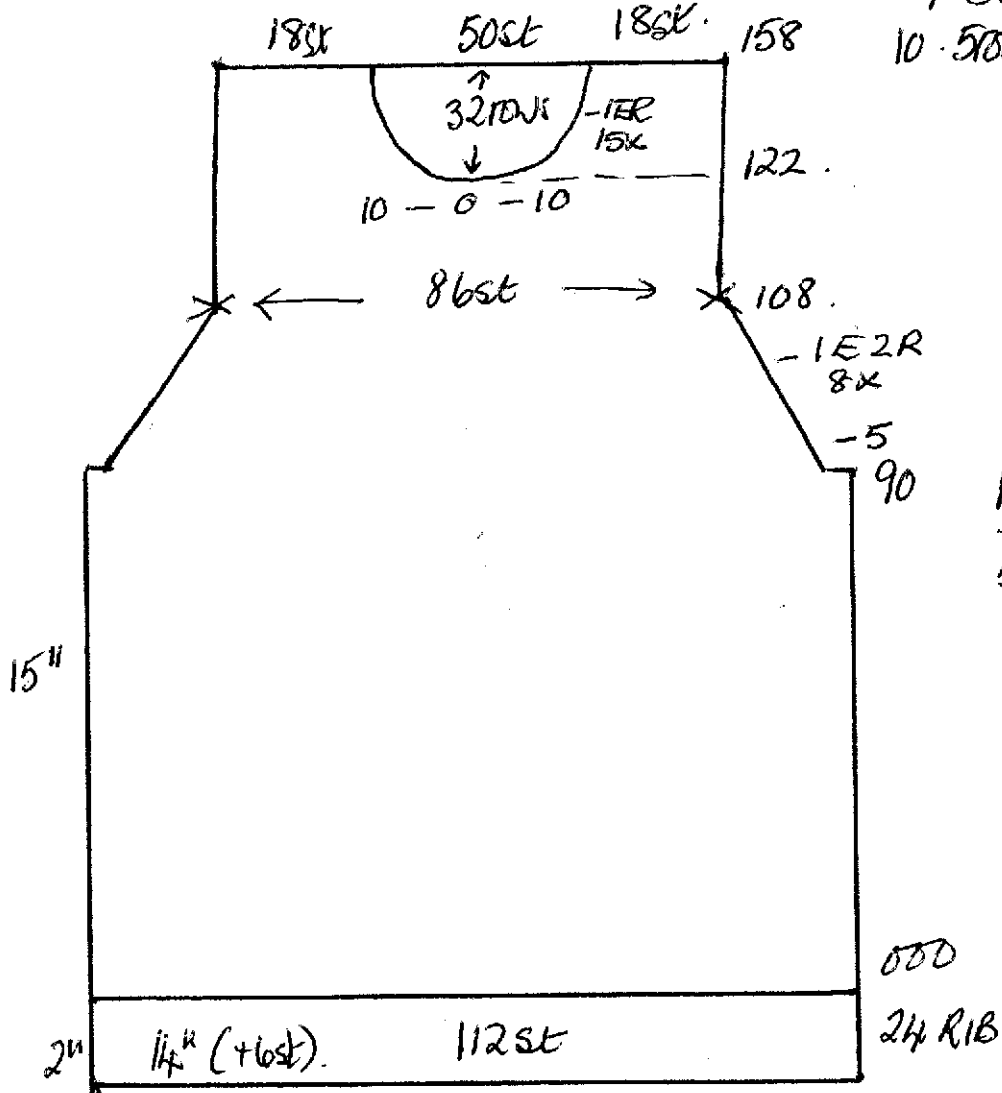

NECKBAND

$$50 + 10 + 50 + 10 = 120st.$$

